

N O Q Q

E N E R G Y

Instruction Manual

Solar Air Source Heat Pump for Swimming Pool

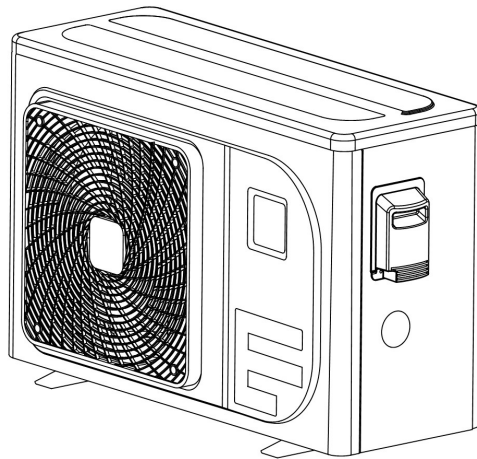

- Installation work should be done by professionals.
- For your convenience, please read this manual carefully and follow the steps in the manual.
- Please keep the manual properly for easy reference.

CONTENTS

1. Preface.....	1
2. Specifications	4
2.1. Performance Data of Swimming Pool Heat Pump Unit	4
2.2. Dimensions of Swimming Pool Heat Pump Unit	5
3. Installation and Connection	6
3.1. Installation illustration	6
3.2. Swimming Pool Heat Pumps Location.....	7
3.3. How Close to Your Pool?	7
3.4. Swimming Pool Heat Pumps Plumbing	7
3.5. Swimming Pool Heat Pumps Electrical Wiring.....	8
3.6. Initial Start-up of the Unit	9
3.7. Installation of Photovoltaic Panels.....	10
4. Use and Operation Instruction of Wire Controller.....	13
4.1. Interface Display.....	13
4.1.1 Display area Description	13
4.1.2 Function Code Description.....	14
4.2. Key and Icon Function Instruction	14
4.2.1 Key Function Instruction	14
4.2.2 Icon Function Instruction	15
4.3. Startup & Shutdown.....	16
4.4. Mode Switch	16
4.5. Temperature Setting.....	16
4.6. Setting of Timing ON/OFF	17
4.7. Mute Setting.....	17
4.7.1 Setting and Cancellation of Timing Mute.....	17
4.7.2 One-click Mute	18
4.8. Clock Setting.....	18
4.9. Keyboard Lock	18
4.10. Forced Frost.....	19
4.11. Pump Forced Operation	19
4.12. WIFI Configuration Operation	19
4.13. Fault Interface	20
5. Maintenance and Inspection	21
6. Appendix	27
6.1. Caution & Warning.....	27
6.2. Cable Specification	27
6.3. Internal Electrical Wiring Diagram	28

1. Preface

- In order to provide our customers with quality, reliability and versatility, this product has been made to strict production standards. This manual includes all the necessary information about installation, debugging, discharging and maintenance. Please read this manual carefully before you open or maintain the unit. The manufacture of this product will not be held responsible if someone is injured or the unit is damaged, as a result of improper installation, debugging, or unnecessary maintenance. It is vital that the instructions within this manual are adhered to at all time. The unit must be installed by qualified personnel.
- The unit can only be repaired by qualified installer centre, personnel or an authorized dealer.
- Maintenance and operation must be carried out according to the recommended time and frequency, as stated in this manual.
- Use genuine standard spare parts only.
Failure to comply with these recommendations will invalidate the warranty.
- Swimming Pool Heat Pump Unit heats the swimming pool water and keeps the temperature constant. For split type unit, The indoor unit can be Discretely hidden or semi-hidden to suit a luxury house.
- Our heat pump has following characteristics:
 - 1) Self-sufficient in electricity
Advanced photovoltaic direct drive technology is adopted to make the power consumption characteristics of the unit consistent with photovoltaic power generation characteristics, so as to ensure the preferential utilization of photovoltaic energy, which is supplemented by the grid Combined with dynamic load tracking MPPT technology to maximize the real-time utilization of photovoltaic energy;
 - 2) AC/DC hybrid technology
Through the AC/DC hybrid control technology, the intelligent seamless switch of "pure photovoltaic, pure commercial power, photovoltaic commercial power hybrid" is realized (switching time < 10ms). Even if the sunshine conditions or the power grid changes dramatically, the unit still runs stably;
 - 3) Full DC frequency conversion technology
Through the efficient DC inverter compressor and DC fan, the full DC control system is used to achieve the best dynamic matching of motor speed, so that the unit runs in the most energy saving state.
 - 4) Intelligent WIFI control
WIFI function is fully controlled, real-time monitoring of the respective power consumption of photovoltaic and mains, and can view historical data by day, month and year units;
 - 5) Wide voltage operation
Grid AC: 150V~260V; PV DC: 80~380V.
The unit can be started in the above wide voltage range and run stably, and low frequency start, small starting current, small impact on the power grid.
 - 6) Reliable operation
The heat exchanger is made of PVC & Titanium tube which can withstand prolonged exposure to swimming pool water. In case of abnormal situation or failure, it can provide self-

protection in time and operate safely and reliably.

7) Precise water temperature control

Electronic expansion valve throttling, PID control, to ensure the stability of the system, reliability, to ensure the end of the water temperature stable, improve the user's comfort experience;

- WARNING

Do not use means to accelerate the defrosting process or to clean, Other than those recommended by the manufacturer.

The appliance shall be stored in a room without continuously operating ignition sources (for example: open flames, an operating gas appliance or an operating electric heater.)



Do not pierce or burn.

Be aware that refrigerants may not contain an odour,

Appliance shall be installed, operated and stored in a room with a floor area larger than 30m².
NOTE The manufacturer may provide other suitable examples or may provide additional information about the refrigerant odour.

- This appliance can be used by children aged from 8 years and above and person with reduced physical, sensory or mental capabilities or lack of experience and knowledge if they have been given supervision or instruction concerning use of the appliance in a safe way and understand the hazards involved. Children shall not play with the appliance. Cleaning and user maintenance shall not be made by children without supervision.
- If the supply cord is damaged, it must be replaced by the manufacturer, its service agent or similarly qualified persons in order to avoid a hazard.
- The appliance shall be installed in accordance with national wiring regulations.
- Do not operate your air conditioner in a wet room such as a bathroom or laundry room.
- Before obtaining access to terminals, all supply circuits must be disconnected.
- An all-pole disconnection device which has at least 3mm clearances in all poles, and have a leakage current that may exceed 10mA, the residual current device(RCD) having a rated residual operating current not exceeding 30mA, and disconnection must be incorporated in the fixed wiring in accordance with the wiring rules.
- Do not use means to accelerate the defrosting process or to clean, other than those recommended by the manufacturer.
- The appliance shall be stored in a room without continuously operating ignition sources (for example: open flames, an operating gas appliance or an operating electric heater.
- Do not pierce or burn.
- Appliance shall be installed, operated and stored in a room with floor area larger than 30m².
Be aware that refrigerants may not contain an odour
The installation of pipe-work shall be kept to a minimum 30 m².

Spaces where refrigerant pipes shall be compliance with national gas regulations.

Servicing shall be performed only as recommended by the manufacturer.

The appliance shall be stored in a well-ventilated area where the room size corresponds to the room area as specified for operation

All working procedure that affects safety means shall only be carried by competent persons.

- Transport of equipment containing flammable refrigerants.

Compliance with the transport regulations.

Marking of equipment using signs.

Compliance with local regulations.

Disposal of equipment using flammable refrigerants.

Compliance with national regulations.

Storage of equipment/appliances.

The storage of equipment should be in accordance with the manufacturer's instructions.

Storage of packed(unsold)equipment.

Storage package protection should be constructed such that mechanical damage to the equipment inside the package will not cause a leak of the refrigerant charge.

The maximum number of pieces of equipment permitted to be stored together will be determined by local regulations.

2. Specifications

2.1. Performance Data of Swimming Pool Heat Pump Unit

Model		10KW	13KW
Rated Grid Power(AC)		208-240V 50/60Hz	208-240V 50/60Hz
Solar Panel Power(DC)		80-380V	80-380V
Heating Capacity(27/24.3℃)	kW	2.1-10.2	2.3-13.6
Heating Power Input	kW	0.14-1.57	0.15-2.09
COP		15.5-6.5	15.8-6.5
Heating Capacity(15/12℃)	kW	1.6-7.3	1.8-9.5
Heating Power Input	kW	0.21-1.52	0.24-1.98
COP		7.7-4.8	7.5-4.8
Max Power consumption	kW	1.92	2.49
Max Current(AC)	A	8.4	10.9
Max Current(DC)	A	12.0	12.0
Water Proof Level		IPX4	IPX4
Electric Shock Prevention		Class I	Class I
Refrigerant		R410A	R410A
Compressor		Rotary	Rotary
Water Side Heat Exchanger		Titanium	Titanium
Air Side Heat Exchanger		Finned tube	Finned tube
Fan Power Input	W	55	55
Fan Direction		Horizontal	Horizontal
Water Connection	mm	50	50
Water Flow Volume	m ³ /h	3.2	4.0
Water Pressure Drop(max)	kPa	5.5	8.0
Noise(1m)	dB(A)	39-51	42-53
Unit Net Dimensions(L/W/H)	mm	995×432×633	995×432×633
Unit Ship Dimensions(L/W/H)	mm	1063×475×695	1063×475×695
Net Weight	kg	45	48
Shipping Weight	kg	50	53
Advised Pool Volume	m ³	25~50	30~70

Heating: Outdoor air temp: 27℃/24.3℃, Inlet water temp: 26℃

Outdoor air temp:15℃/12℃, Inlet water temp:26℃

Operating range:

Ambient temperature:-15-43℃

Water temperature: 10-35℃

Note: Parameters are subject to change without prior notice, please refer to the nameplate !

2.2. Dimensions of Swimming Pool Heat Pump Unit

Model: 10KW, 13kW

unit: mm

NOQQ
ENERGY

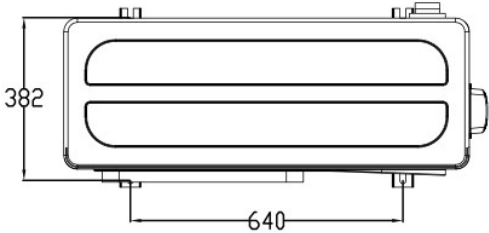
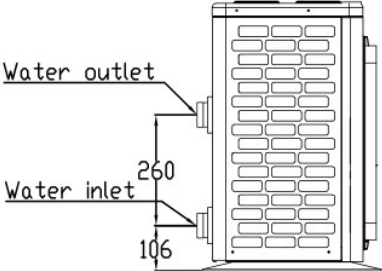
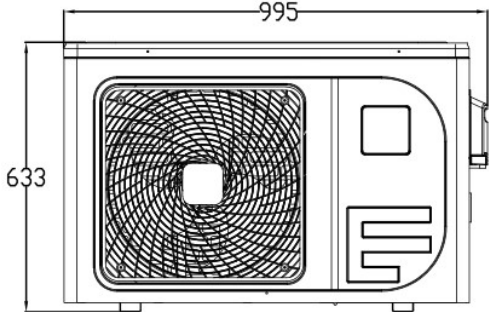
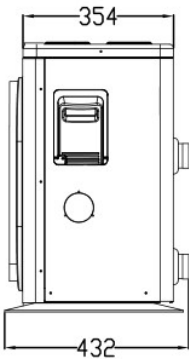

3. Installation and Connection

3.1. Installation illustration

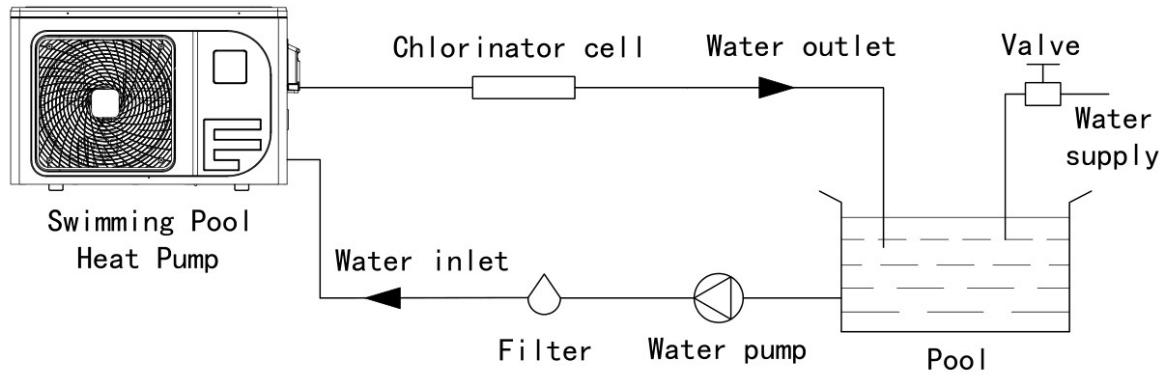

Installation items:

The factory only provides the main unit and the water unit; the other items in the illustration are necessary spare parts for the water system, that provided by users or the installer.

Attention:

Please follow these steps when using for the first time

- 1) Open valve and charge water.
- 2) Make sure that the pump and the water-in pipe have been filled with water.
- 3) Close the valve and start the unit.

ATTN: It is necessary that the water-in pipe is higher than the pool surface.

3.2. Swimming Pool Heat Pumps Location

The unit will perform well in any outdoor location provided that the following three factors are presented:

1. Fresh Air;
2. Electricity;
3. Pool filter piping

The unit may be installed virtually anywhere outdoors. For indoor pools please consult the supplier. Unlike a gas heater, it has no draft or pilot light problem in a windy area.

DO NOT place the unit in an enclosed area with a limited air volume, where the units discharge air will be re-circulated.

DO NOT place the unit to shrubs which can block air inlet. These locations deny the unit of a continuous source of fresh air which reduces its efficiency and may prevent adequate heat delivery.

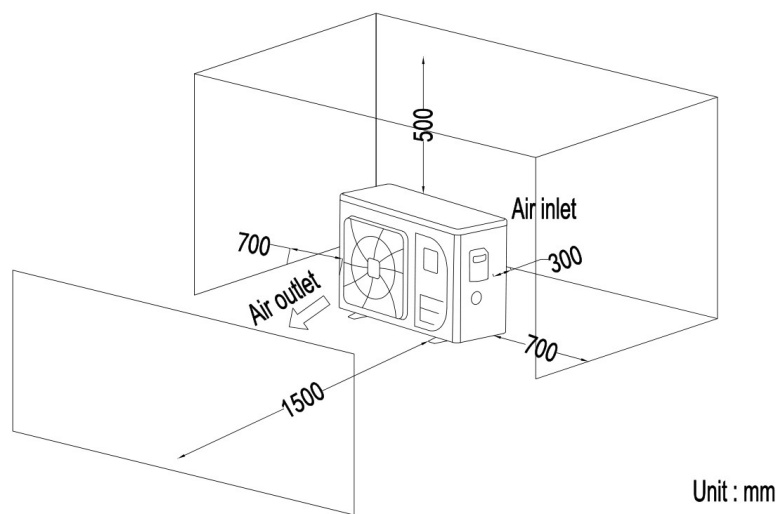

3.3. How Close to Your Pool?

Normally, the pool heat pump is installed within 7.5 metres of the pool. The longer the distance from the pool, the greater the heat loss from the piping. For the most part, the piping is buried. Therefore, the heat loss is minimal for runs of up to 15 meters (15 meters to and from the pump = 30 meters total), unless the ground is wet or the water table is high. A very rough estimate of heat loss per 30 meters is 0.6 kw-hour, (2000BTU) for every 5°C difference in temperature between the pool water and the ground surrounding the pipe, which translates to about 3% to 5% increase in run time.

3.4. Swimming Pool Heat Pumps Plumbing

The Swimming Pool Heat Pumps exclusive rated flow titanium heat exchanger requires no special plumbing arrangements except bypass (please set the flow rate according to the nameplate). The water pressure drops less than 10KPa at max. Flow rate. Since there is no residual heat or flame temperatures. The unit does not need copper heat sink piping. PVC pipe can be run straight into the unit.

Location: Connect the unit in the pool pump discharge (return) line downstream of all filter and pool pumps and upstream of any chlorinators, ozonators or chemical pumps.

Standard model has slip glue fittings which accept 32mm or 50 mm PVC pipe for connection to the pool or spa filtration piping. By using a 50NB to 40NB you can plumb 40NB.

Give serious consideration to adding a quick coupler fitting at the unit inlet and outlet to allow easy draining of unit for winterizing and to provide easier access should servicing be required.

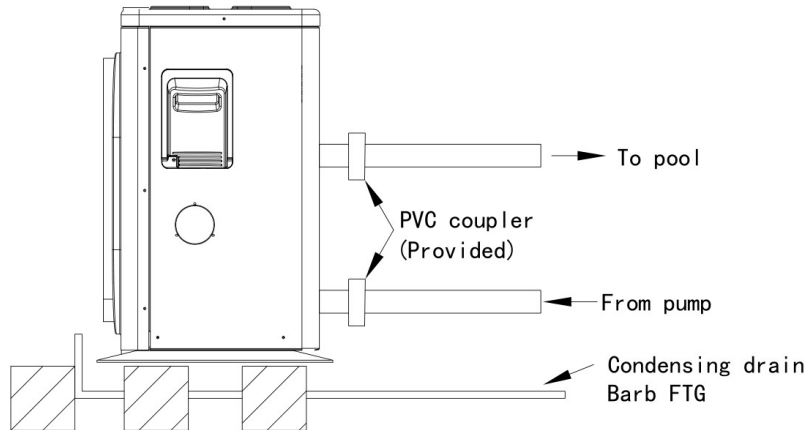

Condensation: Since the Heat pump cools down the air about 4-5°C, water may condense on the fins of the horseshoe shaped evaporator. If the relative humidity is very high, this could be as much as several litres an hour. The water will run down the fins into the basepan and drain out through the barbed plastic condensation drain fitting on the side of the basepan. This fitting is designed to accept 20mm clear vinyl tubing which can be pushed on by hand and run to a suitable drain, It is easy to mistake the condensation for a water leak inside the unit.

NB: A quick way to verify that the water is condensation is to shutoff the unit and keep the pool pump running. If the water stops running out of the basepan, it is condensation. ANEVEN QUICKER WAYIS to TEST THE DRAIN WATER FOR CHLORINE- if the is no chlorine present, then it's condensation.

3.5. Swimming Pool Heat Pumps Electrical Wiring

NOTE: Although the unit heat exchanger is electrically isolated from the rest of the unit, it simply prevents the flow of electricity to or from the pool water. Grounding the unit is still required to protect you against short circuits inside the unit. Bonding is also required.

The unit has a separate molded-in junction box with a standard electrical conduit nipple already in place. Just remove the screws and the right plastic handle, feed your supply lines in through the conduit nipple and wire-nut the electric supply wires to the three connections already in the junction box (four connections if three phase). To complete electrical hookup connect Heat Pump by electrical conduit, UF cable or other suitable means as specified (as permitted by local electrical authorities) to a dedicated AC power supply branch circuit equipped with the proper circuit breaker, disconnect or time delay fuse protection.

Disconnect-A disconnect means (circuit breaker, fused or un-fused switch) should be located

within sight of and readily accessible from the unit. This is common practice on commercial and residential air conditioners and heat pumps. It prevents remotely-energizing unattended equipment and permits turning off power at the unit while the unit is being serviced.

Electrical wiring:

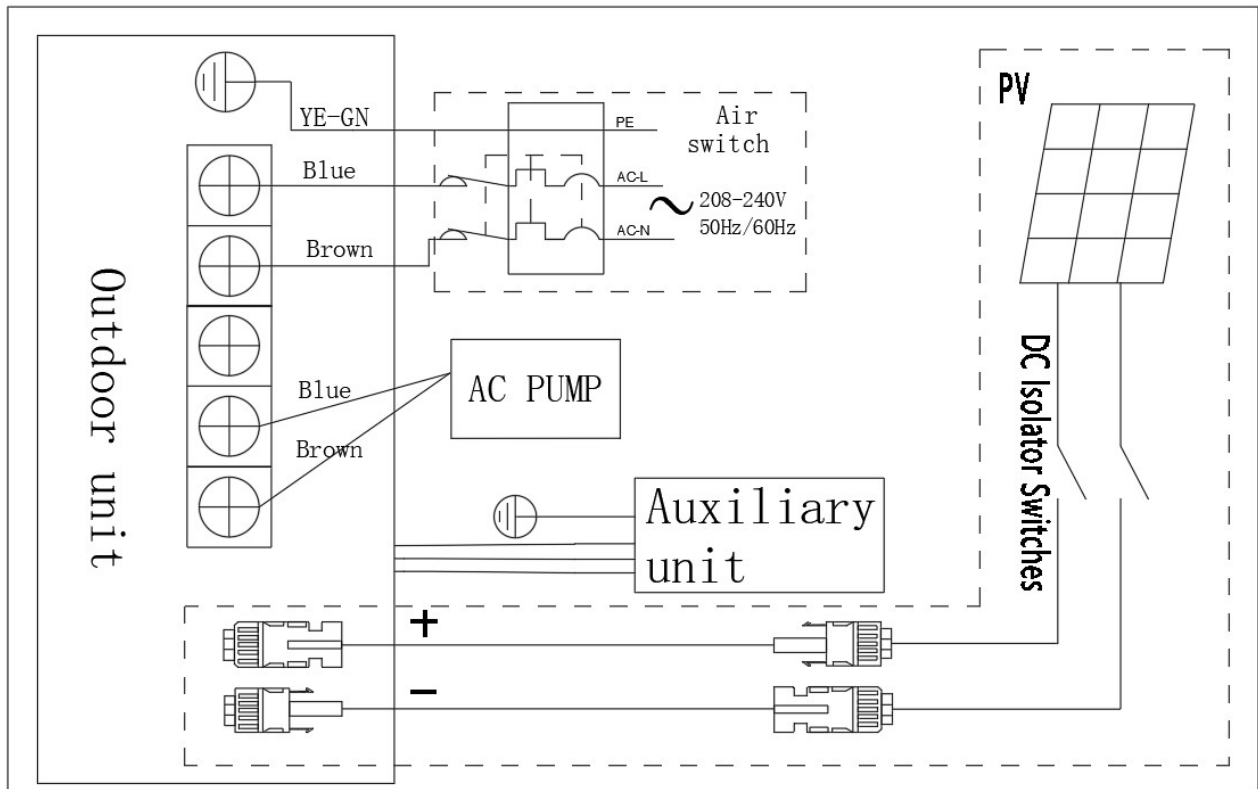

Note: if there is any change due to product improvement, the unit's internal label shall prevail.

3.6. Initial Start-up of the Unit

NOTE: In order for the unit to heat the pool or spa, the filter pump must be running to circulate water through the heat exchanger.

Start-up procedure: After installation is completed, you should follow these steps:

1. Turn on your filter pump. Check for water leaks and verify flow to and from the pool.
2. Turn on the electrical power supply to the unit, then press the key ON/OFF of wire controller, It should start in several seconds.
3. After running a few minutes make sure the air leaving the top (side) of the unit is cooler. (Between 5-10°C)
4. With the unit operating turn the filter pump off. The unit should also turn off automatically.
5. Allow the unit and pool pump to run 24 hours per day until desired pool water temperature is reached. When the water-in temperature rises more then 1.5°C above this setting, the unit will slow down for a period of time, if the temperature is maintained for 60 minutes the unit will turn off. The unit will now automatically restart (as long as your pool pump is running) when the pool temperature drops below set temperature.

Time Delay- The unit is equipped with a 3-minute built-in solid state restart delay included to protect control circuit components and to eliminate restart cycling and contactor chatter. This time delay will automatically restart the unit approximately 3 minutes after each control circuit interruption. Even a brief power interruption will activate the solid state 3 minute restart delay and prevent the unit from starting until the 3 minute countdown is completed.

3.7. Installation of Photovoltaic Panels

1. Disclaimer

With the update of Volta technology, the relevant information of the existing manual will be improved without notice. This manual is only for land installation, users and installers. should carefully read and abide by it.

2. General safety rules

- The installation of solar photovoltaic power generation system requires specialized skills and knowledge, which must be completed by a professionally qualified engineer.
- When the installer tries to install, operate and maintain the photovoltaic modules, please make sure that you fully understand the information in this installation instruction manual and understand the risk of injury that may occur during the installation process.
- Photovoltaic modules produce electricity when there is sufficient sunlight or other light sources. When operating, please take corresponding protective measures to avoid direct contact with 30VDC or higher voltage.
- Solar photovoltaic modules can convert light energy into direct current electricity, and the amount of electricity will change with the change of light intensity.
- When the component has current or has an external power supply, the component must not be connected or disconnected.
- When installing, using modules or wiring, opaque materials should be used to cover the front of the modules in the solar photovoltaic module array to stop power generation.
- All local, regional and national laws and regulations shall be complied with, and construction permits shall be obtained first if necessary.
- There are no user-repairable originals for solar photovoltaic modules. Do not disassemble, move or modify any attached parts.
- Do not wear metal rings, watch straps, earrings, nose rings, lip rings or other metal accessories when installing solar photovoltaic modules.
- Please do not install or operate the module when it is humid or windy.
- Do not use or install damaged components, and do not artificially condense light on the components.
- Only PV modules of the same model can be combined together. Avoid uneven shadows on the surface of photovoltaic modules. The shaded cells can become hot (the "hot spot" effect), which can cause permanent damage to the components.
- When an accident occurs, please turn off the isolating switch immediately.
- Defective or damaged components may still emit electricity. If you need to transport, please take measures to cover to ensure that the components are completely shaded.
- Keep children away from the module when transporting and installing the module.
- Please keep the photovoltaic modules in the original packing box before installation.

3. Select location

- The location where the module is installed should not be shaded or blocked all year round, and have sufficient sunlight.
- Solar photovoltaic modules generate electricity by light, please choose an appropriate installation angle to ensure that the modules can get the maximum amount of sunlight.
- The selection of module location should meet the requirements of various electrical and fire protection codes.
- Choosing a bracket
 - 1) The instructions and safety rules attached to the bracket should be followed.
 - 2) When the components leave the factory, the design has been completed. Please do not try to change the component structure or construction, etc.
 - 3) For standard installation, use the four symmetrical mounting holes on the inner side of the frame to fix the module on the bracket.
 - 4) The bracket and other required materials (such as bolts, etc.) should be made of durable, anti-corrosion, and anti-ultraviolet materials.
- Land installation
 - 1) When installing on the ground, choose a suitable installation height to prevent the lower part of the module from being covered by snow for a long time when it snows in winter. In addition, make sure that the lowest part of the module is high enough to avoid being blocked by plants or trees or being damaged by blowing sand.
 - 2) Check the building codes used during roof installation to ensure that the building and its structure (roof, exterior, load-bearing, etc.) to be installed have sufficient bearing capacity. When installing modules, make sure that the modules are installed on a fire-proof roof, and the roof inclination angle is less than 5in/ft, to ensure its fireproof level.
 - 3) When the module is installed on the roof or building, make sure that it is securely fixed and will not be damaged by strong wind or heavy snow.
 - 4) Ensure smooth ventilation on the back of the module (the minimum distance between the module and the mounting surface is 10cm).
 - 5) When installing on the roof, the roof that needs to be penetrated when installing the fixed components should be properly sealed to prevent leakage.

4. Installation Guide

- The components and supporting structure should be fixed with bolts through the mounting holes, which are only located at the rear flange position of the frame. No additional drilling is required.
- Use appropriate anti-corrosion fastening materials.
- There are many different ways to tighten up or down, and the installation method depends on the installation structure.
- The installation design should be checked by a professional engineer. Installation design and procedures should comply with local regulations and all legal functions.
- A torque wrench should be used during installation

5. Electrical installation

In some cases, the current or voltage generated by the component may be greater than the optimal operating current or voltage under its standard test conditions (STC). Therefore, when determining the original rating and load value, the open circuit voltage and open circuit current

of the component under STC should be multiplied by 1.25. When determining the appropriate wire and fuse, the short-circuit current should be multiplied by 1.25 in accordance with Section 690-8 of the USNEC.

Electrical installation details:

- Components with the same configuration should be used on the same photovoltaic power generation system.
- If photovoltaic modules are connected in series, the total voltage is equal to the sum of the voltage of each module.
- If PV modules are connected in parallel, the total current is equal to the sum of the current of each module.
- Components provide prefabricated connectors for electrical connection of the system.
- The cross-sectional area and connector capacity of the selected cables should meet the maximum short-circuit current of the system.
- Install the components with one end with a junction box on the back facing upwards.
- Loop should be avoided when designing the system.
- Check whether the wiring is correct before starting.
- Ensure that the connection is secure and tight, and the plug shall not bear external pressure. It can only be used to connect the line, and shall not be used to open or close the circuit.
- Components and component support shall be properly grounded. Use the recommended connection terminals and connect the ground cable properly.
- You are advised to use a ground cable accessory (wiring nose) to connect the ground cable.
- All contacts in conducting connections shall be secured. Ferrous metals used in conductive connections should be treated with corrosion protection to prevent rust.

6. Recommended amount of photovoltaic panels

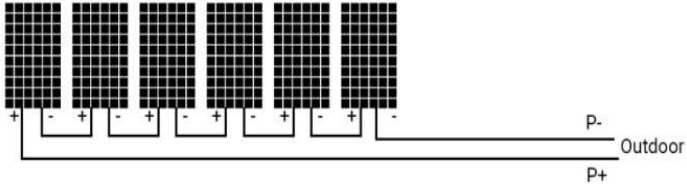
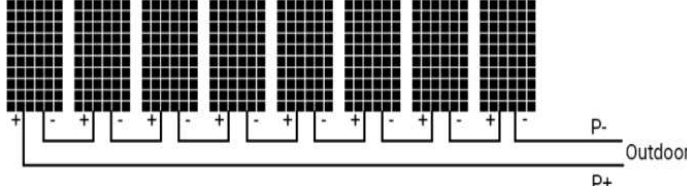
Model	Connection of photovoltaic panels	Recommended amount
10KW		(280-360W) 6 pcs (360-450W) 5 pcs
13KW		(280-360W) 8 pcs (360-450W) 7 pcs

4. Use and Operation Instruction of Wire Controller

4.1. Interface Display

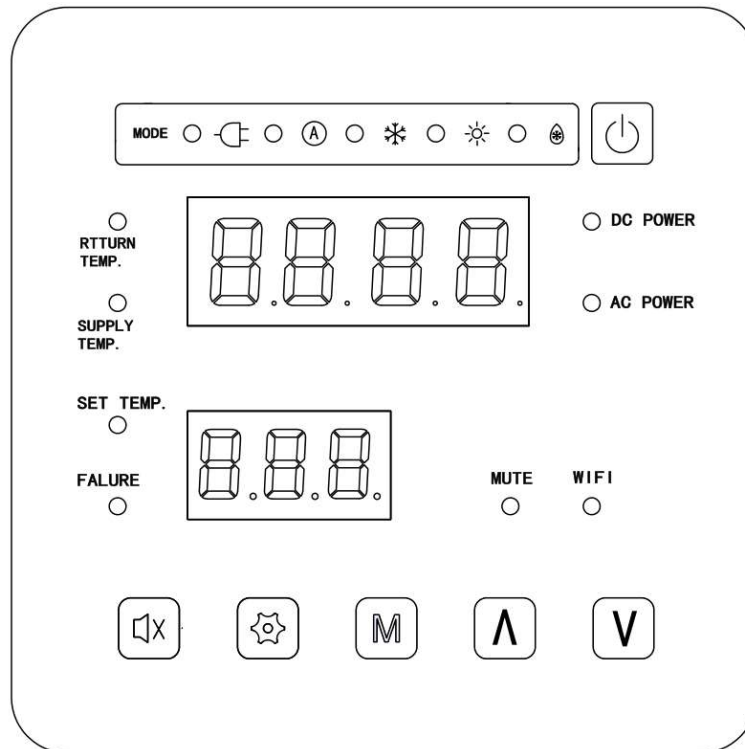

4.1.1 Display area Description

1) Main display area :

- ① Under the main interface, the water inlet temperature, water outlet temperature, AC power and DC power are displayed circularly (interval: 5 seconds).
- ② In the process of anti-freezing or forced operation of water pump, the corresponding code flash (interval of 2 seconds)

2) Auxiliary display area

- ① In shutdown state, it shows OFF
- ② After the unit is started, the set temperature is always displayed when there is no fault
- ③ If there is a fault, the current fault code will be displayed (interval 1 second)

3) Other instructions

- ① When parameter selection is involved, parameter items are displayed in the auxiliary display area and parameter values are displayed in the main display area
- ② When querying status parameters, parameter serial number is displayed in the auxiliary display area and parameter value is displayed in the main display area

4.1.2 Function Code Description

Function code comparison table:

Function	Parameters of the code	Display code
WIFI configured	UU	/
Clock setting	CL	/
Status Parameter Query	PA	/
Forced frost	FD	/
Pump forced operation	PF	BBBB
Freeze protection operation	FP	AAAA

4.2. Key and Icon Function Instruction

4.2.1 Key Function Instruction

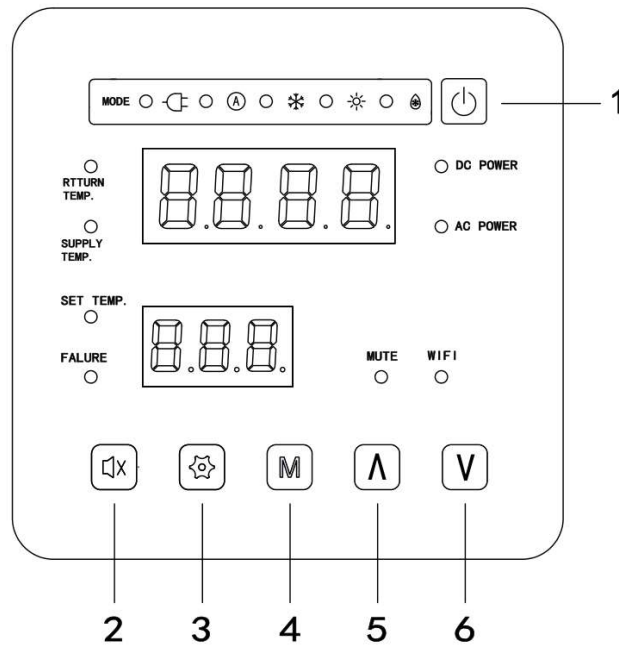

No.	designation	function
1	On-off key	<ul style="list-style-type: none"> ■ Main interface: Long press for 0.5 seconds to turn on/off. ■ Main interface: Long press for 5 seconds to lock/unlock the screen. ■ Other interface: Short press to cancel the current operation and return to the previous operation.
2	Mute key	<ul style="list-style-type: none"> ■ Main interface: Short press to enter or exit the one-button mute function. ■ Main interface: Long press for 5 seconds to enter the timer mute setting.
3	Setting key	<ul style="list-style-type: none"> ■ Main interface: Short press to enter user setting selection. ■ Main interface: Long press for 5 seconds to enter or exit the one-key power limiting function. ■ Other interface: Short press to set parameters, function Settings and save.

4	Mode key	<ul style="list-style-type: none"> ■ Main interface: Short press to switch mode. ■ Main interface: Long press for 5 seconds to set timing.
5	Up key	<ul style="list-style-type: none"> ■ It is used to increase or decrease variable value. ■ Main interface: Long press "up" and "Down" keys for 3 seconds to enter special function setting selection.
6	Down key	

4.2.2 Icon Function Instruction

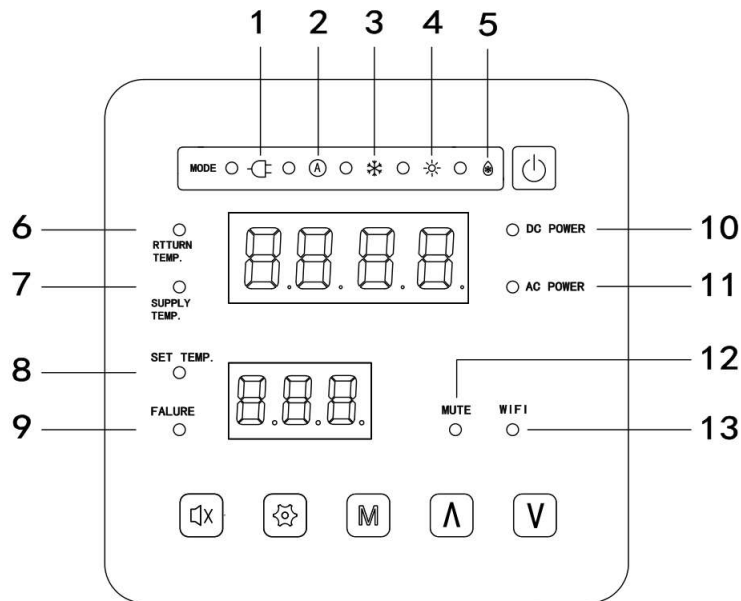

No.	designation	function
1	Power limiting symbol	When The power limiting function is enabled, the light is on
2	Automatic symbol	it will display under the automatic mode
3	Cooling symbol	It will display during cooling
4	Heating symbol	It will display during heating
5	Defrosting symbol	It will display in the defrosting process of the unit
6	Water inlet symbol	When the main display area displays the water inlet temperature, the light is on
7	Water outlet symbol	When the main display area displays the water outlet temperature, the light is on
8	Setting symbol	When the auxiliary display area displays the water setting temperature, the light is on. When the parameter is adjustable , it is on.
9	Fault symbol	In case of unit fault ,it is on
10	DC power symbol	When the main display area displays the Real-time DC power, it is on
11	AC power symbol	When the main display area displays the Real-time AC power, it is on
12	Mute symbol	When it is in mute state, the light is on
13	WIFI symbol	When the WIFI is successfully configured, the light is on (The light blinks during the WIFI configuration)

4.3. Startup & Shutdown

In the main interface, keep long press of “” for 0.5 seconds to enter ON/OFF interface. When there is no operation within 1 minute, the screen is automatically extinguished. When it displays full screen off, click any key for returning to ON/OFF main interface.

Notes:

- Startup & shutdown operation can only be conducted in the main interface.
- When linkage switch mode is 1 or 2:
 - 1) When the linkage switch is disconnected, the secondary display screen displays "LFF".
 - 2) When the linkage switch is closed, the sub-display screen will display normally. (the startup state will display the set temperature, and the shutdown state will display OFF)

4.4. Mode Switch

Under the main interface, Short press “” to switch the unit among heating, cooling and automatic mode.





Operation descriptions:

- Mode switch operation can only be conducted in the main interface.
- When the unit is under the defrosting state, the system automatically returns to the pre-defrosting mode after the defrosting is finished.
- During the defrosting, mode switch is available. And when switching the mode, the unit won't work under a new mode until defrosting is completed.

4.5. Temperature Setting

The unit adopts backwater temperature control, and the corresponding target setting temperature default value and adjustable range in each mode are as follows:

Mode	Default value	Adjustable range
Cooling	27°C	10~35°C
Heating	27°C	15~35°C
Automatic	27°C	10~35°C









In the main interface, press “” or “” for entering the temperature setting interface, and the temperature setting icon blinks → press “” or “” to increase/decrease the temperature setting value → press “” to save the setting and return to the previous interface.

Notes: Under the temperature setting interface, if short press “” the system will return to the main interface without any changes saved; If there is no operation for 5 seconds, the system will automatically memorize user's setting, and return to the main interface.

4.6. Setting of Timing ON/OFF

At present, the wire controller can only realize the timing setting of one time period in one day. Users can set the opening or closing time as well as the opening and closing time for each period according to their own requirements.

Setting steps:

1. Long press “” for 5 seconds. the timer setting interface is displayed. Short press “” or “” to select parameters between v03-V08.
2. After selecting a parameter, short press “” to enter the hour/minute or timer switch enablement setting (the corresponding parameter value blinks), Short press “” or “” to adjust the setting value.
3. Click “” Save settings, click “” for returning to the main interface.









Notes: If there is no operation for 20 seconds, the system will automatically memorize user’s setting, and return to the main interface.

Parameter No.	Parameter meaning	Parameter range
V03	Hour bit of timing boot 1	0-23
V04	Minute bit of timing boot 1	00/10/20/30/40/50
V05	Whether to enable timed boot 1	Not enable,1- enable
V06	Hour bit of timed shutdown 1	0-23
V07	Minute bit of timed shutdown 1	00/10/20/30/40/50
V08	Whether to enable timed shutdown 1	0- Not enable,1- enable

4.7. Mute Setting

4.7.1 Setting and Cancellation of Timing Mute

Setting steps:

1. Long press “” for 5 seconds. The mute setting interface is displayed. Short press “” or “” to select parameters between F14-F18.
2. After selecting a parameter, short press “” to enter the start/end or enable setting of timing mute, then short press “” or “” to adjust the setting value.
3. Click “” Save settings, click “” for returning to the main interface.

Notes: If there is no operation for 20 seconds, the system will automatically memorize user’s setting, and return to the main interface.

Parameter No.	Parameter meaning	Parameter range
F14	Timing mute start time(hour)	0-23
F15	Timing mute start time(minute)	00/10/20/30/40/50
F16	Timed mute end time(hour)	0-23

F17	Timing mute end time(minute)	00/10/20/30/40/50
F18	Whether to enable timed mute	0-Not enable, 1- enable











4.7.2 One-click Mute

In the main interface, short press “” to enter or exit the one-button mute setting.

Notes: At night or the rest time, user can start one-click mute or timing mute function to reduce the noise.

4.8. Clock Setting

Setting steps:

1. In the main interface, short press “” for entering user setting interface.
2. Short press “” or “” to select parameter “CL”, then short press “” for entering clock setting interface.
3. Short press “” or “” to select parameters between V01-V02.
4. After selecting a parameter, short press “” to enter the hour/minute setting, Short press “” or “” to adjust the setting value.
5. Click “” Save settings, click “” for returning to the main interface.

Notes: If there is no operation for 20 seconds, the system will automatically memorize user’s setting, and return to the main interface.

Parameter No.	Parameter meaning	Parameter range
V01	Hour bit of clock	0-23
V02	Minute bit of clock	0-59

4.9. Keyboard Lock





To avoid others' misoperation, please lock the wire controller after completing the setting.

Keep long press of “” for 5 seconds to lock or unlock the screen.

Notes:

- Under the locked screen interface, only unlocking operation is available, and the screen will be lightened after other operations conducted.
- Under the OFF interface, locking operation is available, and the operation method is the same as locking screen under the ON interface.
- After the key is locked, the default display the time (the auxiliary display area shows hour, the main display shows minute).
- After the key is locked, in the case of failure, the auxiliary display area shows failure code, the main display is off.





4.10. Forced Frost

During heating operation, long press “” and “” for 3 seconds at the same time in the main interface to enter the function selection interface. After selecting parameter group "FD" by short pressing “” or “”, then press “” to enter the forced defrosting interface (if manual defrosting conditions are met).







Note:

- Forced defrosting can only be entered if the entry conditions for mandatory defrosting are met.
- When the exit conditions are met, the defrosting will exit automatically.

4.11. Pump Forced Operation

In shutdown state, long press “” and “” for 3 seconds at the same time in the main interface to enter the function selection interface. After selecting parameter group "PF" by short pressing “” or “”, then press “” to start/cancel the forced operation of the pump.

4.12. WIFI Configuration Operation

1. Setting steps
On the main interface, short pressing “” or “” to enter the user setting interface. After selecting parameter group "UU" by short pressing “” or “”, then press “” to enter WIFI network function, WIFI indicator blinks.
2. In the interface of network configuration selection, long press “” for a long time. When the wire controller automatically jumps to the main interface, release the button.
3. If the WIFI connection is successful, the WIFI indicator on the wireline controller will no longer blink and become steady on; If it is not connected within 3 minutes, the indicator will stop blinking and turn off.
4. Triggering the network will reset the network information, and the network mode will be switched between "Hotspot network (Compatible mode)" and "Bluetooth network".

Note:

- Restart the networking mode if the device fails to connect to the Internet within 3 minutes.
- If the network configuration fails for several times and the cloud cannot be connected, check whether the WIFI password is correct, the WIFI network is 2.4 GB, and the network communication is normal.
- If some models fail to connect to the Internet, unplug the device for five seconds and then plug it in again and try again.

4.13. Fault Interface

When the unit fails, the current fault code will be displayed in the auxiliary display area of the wire controller according to the fault reason. Refer to the fault table for the specific definition of the fault codes.

Protect/fault	Code	Reason	Elimination methods
Indoor EEPROM Error warn	01	MCU error	Check whether the chip is damaged . Replace the chip
Internal and external communication failure	03	Communication failure between Internal and external mainboard	check the connection between internal and external mainboard
Outdoor EEPROM Error warn	05	MCU error	Check whether the chip is damaged . Replace the chip
Flow switch protection	11	No water/little water in water system	Check the pipe water flow and water pump
Inlet and outlet water temp. too big	12	Water flow is not enough and low differential pressure	Check the pipe water flow and whether water system is jammed or not
Inlet water temp. too low (cooling)	13	Inlet water temp.is too low	
Outlet water temp. too high (cooling)	14	Outlet water temp.is too high	
Water flow switch against short circuit protection	15	The flow switch is short-circuited	Check the water flow switch
Inner coil temp. too high	20	Inner coil temp.is too high	
External coil temp. too high	21	External coil temp. is too high	
Exhaust air over temp prot.	22	The compressor is overload	Check whether the system of compressor running normally
Anti-freezing prot.	23	Water flow is not enough	Check the pipe water flow and whether water system is jammed or not
High pressure prot.	24	The high-pressure switch is broken	Check the pressure switch and cold circuit
Low pressure prot.	25	Low pressure 1 protection	Check the pressure switch and cold circuit
Inter temp. sensor fault	31	The temp. Sensor is broken or short circuit	Check or change the temp. Sensor
Outler temp. sensor fault	32	The temp. Sensor is broken or short circuit	Check or change the temp. Sensor
Inner coil temp. sensor fault	33	The temp. Sensor is broken or short circuit	Check or change the temp. Sensor
Ambient temp. sensor fault	35	The temp. Sensor is broken or short circuit	Check or change the temp. Sensor

External coil temp. sensor fault	36	The temp. Sensor is broken or short circuit	Check or change the temp. Sensor
Discharge temp. sensor fault	37	The temp. Sensor is broken or short circuit	Check or change the temp. Sensor
DC fan fault	58	Motor current feedback open circuit or short circuit	check whether current return wires connected motor
Overcurrent protection	73	The compressor is overload	Check whether the system of compressor running normally
Compressor stall failure	93		
IPM Overcurrent	95		
Oil return failure protection	98		
Compressor low speed protection	99	In the pure photovoltaic state, the light is not enough	

5. Maintenance and Inspection

- Check the water supply device and the release often. You should avoid the condition of no water or air entering into system, as this will influence unit's performance and reliability. You should clear the pool/spa filter regularly to avoid damage to the unit as a result of the dirty or clogged filter.
- The area around the unit should be dry, clean and well ventilated. Clean the side heating exchanger regularly to maintain good heat exchange as conserve energy.
- The operation pressure of the refrigerant system should only be serviced by a certified technician.
- Check the power supply and cable connection often. Should the unit begin to operate abnormally, switch it off and contact the qualified technician.
- Discharge all water in the water pump and water system, so that freezing of the water in the pump or water system does not occur. You should discharge the water at the bottom of water pump if the unit will not be used for an extended period of time. You should check the unit thoroughly and fill the system with water fully before using it for the first time after a prolonged period of no usage.
- Checks to the area
 - Prior to beginning work on systems containing flammable refrigerants, safety checks are necessary to ensure that the risk of ignition is minimized. For repair to the refrigerating system, the following precautions shall be complied with prior to conducting work on the system.
- Work procedure
 - Work shall be undertaken under a controlled procedure so as to minimize the risk of a

flammable gas or vapour being present while the work is being performed.

- General work area

All maintenance staff and others working in the local area shall be instructed on the nature of work being carried out. Work in confined spaces shall be avoided. The area around the workspace shall be sectioned off. Ensure that the conditions within the area have been made safe by control of flammable material.

- Checking for presence of refrigerant

The area shall be checked with an appropriate refrigerant detector prior to and during work to ensure the technician is aware of potentially flammable atmospheres. Ensure that the leak detection equipment being used is suitable for use with flammable refrigerants, i.e. non-sparking, adequately sealed or intrinsically safe.

- Presence of fire extinguisher

If any hot work is to be conducted on the refrigeration equipment or any associated parts appropriate fire extinguishing equipment shall be available to hand. Have a dry powder or CO₂ fire extinguisher adjacent to the charging area.

- No ignition sources

No person carrying out work in relation to a refrigeration system which involves exposing any pipe work that contains or has contained flammable refrigerant shall use any sources of ignition in such a manner that it may lead to the risk of fire or explosion. All possible ignition sources, including cigarette smoking, should be kept sufficiently far away from the site of installation, repairing, removing and disposal, during which flammable refrigerant can possibly be released to the surrounding space. Prior to work taking place, the area around the equipment is to be surveyed to make sure that there are no flammable hazards or ignition risks. "No Smoking" signs shall be displayed.

- Ventilated area

Ensure that the area is in the open or that it is adequately ventilated before breaking into the system or conducting any hot work. A degree of ventilation shall continue during the period that the work is carried out. The ventilation should safely disperse any released refrigerant and preferably expel it externally into the atmosphere. Prolonged period of no usage.

- Checks to the refrigeration equipment

Where electrical components are being changed, they shall be fit for the purpose and to the correct specification. At all times the manufacturer's maintenance and service guidelines shall be followed. If in doubt consult the manufacturer's technical department for assistance.

The following checks shall be applied to installations using flammable refrigerants:

- 1) The charge size is in accordance with the room size within which the refrigerant containing parts are installed.
- 2) The ventilation machinery and outlets are operating adequately and are not obstructed.
- 3) If an indirect refrigerating circuit is being used, the secondary circuit shall be checked for the presence of refrigerant.
- 4) Marking to the equipment continues to be visible and legible. Markings and signs that are

illegible shall be corrected.

- 5) Refrigeration pipe or components are installed in a position where they are unlikely to be exposed to any substance which may corrode refrigerant containing components, unless the components are constructed of materials which are inherently resistant to being corroded or are suitably protected against being so corroded.

- Checks to electrical devices

Repair and maintenance to electrical components shall include initial safety checks and component inspection procedures. If a fault exists that could compromise safety, then no electrical supply shall be connected to the circuit until it is satisfactorily dealt with. If the fault cannot be corrected immediately but it is necessary to continue operation, an adequate temporary solution shall be used. This shall be reported to the owner of the equipment so all parties are advised.

Initial safety checks shall include:

- 1) That capacitors are discharged: this shall be done in a safe manner to avoid possibility of Sparking.
- 2) That there no live electrical components and wiring are exposed while charging recovering or purging the system.
- 3) That there is continuity of earth bonding.

- Repairs to sealed components

- 1) During repairs to sealed components, all electrical supplies shall be disconnected from the equipment being worked upon prior to any removal of sealed covers, etc. If it is absolutely necessary to have an electrical supply to equipment during servicing, then a permanently operating form of leak detection shall be located at the most critical point to warn of a potentially hazardous situation.
- 2) Particular attention shall be paid to the following to ensure that by working on electrical components, the casing is not altered in such a way that the level of protection is affected. This shall include damage to cables, excessive number of connections, terminals not made to original specification, damage to seals, incorrect fitting of glands, etc.
- 3) Ensure that apparatus is mounted securely.
- 4) Ensure that seals or sealing materials have not degraded such that they no longer serve the purpose of preventing the ingress of flammable atmospheres. Replacement parts shall be in accordance with the manufacturer's specifications.

NOTE: The use of silicon sealant may inhibit the effectiveness of some types of leak detection equipment. Intrinsically safe components do not have to be isolated prior to.

- Repair to intrinsically safe components

Do not apply any permanent inductive or capacitance loads to the circuit without ensuring that this will not exceed the permissible voltage and current permitted for the equipment in use.

Intrinsically safe components are the only types that can be worked on while live in the presence of a flammable atmosphere. The test apparatus shall be at the correct rating.

Replace components only with parts specified by the manufacturer. Other parts may result in the ignition of refrigerant in the atmosphere from a leak.

- **Cabling**
Check that cabling will not be subject to wear, corrosion, excessive pressure, vibration, sharp edges or any other adverse environmental effects. The check shall also take into account the effects of aging or continual vibration from sources such as compressors or fans.

- **Detection of flammable refrigerants**
Under no circumstances shall potential sources of ignition be used in the searching for or detection of refrigerant leaks. Halide torch (or any other detector using a naked flame) shall not be used.

- **Leak detection methods**
The following leak detection methods are deemed acceptable for systems containing flammable refrigerants.
Electronic leak detectors shall be used to detect flammable refrigerants, but the sensitivity may not be adequate, or may need re-calibration. (Detection equipment shall be calibrated in a refrigerant-free area.) Ensure that the detector is not a potential source of ignition and is suitable for the refrigerant used. Leak detection equipment shall be set at a percentage of the LFL of the refrigerant and shall be calibrated to the refrigerant employed and the appropriate percentage of gas (25% maximum) is confirmed.
Leak detection fluids are suitable for use with most refrigerants but the use of detergents containing chlorine shall be avoided as the chlorine may react with the refrigerant and corrode the copper pipe-work.
If a leak is suspected, all naked flames shall be removed/ extinguished.
If a leakage of refrigerant is found which requires brazing, all of the refrigerant shall be recovered from the system, or isolated (by means of shut off valves) in a part of the system remote from the leak. Oxygen free nitrogen (OFN) shall then be purged through the system both before and during the brazing process.

- **Removal and evacuation**
When breaking into the refrigerant circuit to make repairs or for any other purpose conventional procedures shall be used. However, it is important that best practice is followed since flammability is a consideration. The following procedure shall be adhered to:
 - Remove refrigerant;
 - Purge the circuit with inert gas;
 - Evacuate;
 - Purge again with inert gas;
 - Open the circuit by cutting or brazing;
 The refrigerant charge shall be recovered into the correct recovery cylinders. The system shall be "flushed" with OFN to render the unit safe. This process may need to be repeated several times, Compressed air or oxygen shall not be used for this task.
Flushing shall be achieved by breaking the vacuum in the system with OFN and continuing to fill until the working pressure is achieved, then venting to atmosphere, and finally pulling down to a vacuum. This process shall be repeated until no refrigerant is within the system.
When the final OFN charge is used, the system shall be vented down to atmospheric pressure to enable work to take place. This operation is absolutely vital if brazing operations on the pipe-work are to take place.

Ensure that the outlet for the vacuum pump is not close to any ignition sources and there is ventilation available. Working on them.

- Labelling

Equipment shall be labelled stating that it has been de-commissioned and emptied of refrigerant. The label shall be dated and signed. Ensure that there are labels on the equipment stating the equipment contains flammable refrigerant.

- Recovery

When removing refrigerant from a system, either for servicing or decommissioning, it is recommended good practice that all refrigerants are removed safely.

When transferring refrigerant into cylinders, ensure that only appropriate refrigerant recovery cylinders are employed. Ensure that the correct number of cylinders for holding the total system charge is available. All cylinders to be used are designated for the recovered refrigerant and labelled for that refrigerant (i.e. special cylinders for the recovery of refrigerant). Cylinders shall be complete with pressure relief valve and associated shut off valves in good working order. Empty recovery cylinders are evacuated and, if possible, cooled before recovery occurs.

The recovery equipment shall be in good working order with a set of instructions concerning the equipment that is at hand and shall be suitable for the recovery of flammable refrigerants. In addition, a set of calibrated weighing scales shall be available and in good working order. Hoses shall be complete with leak-free disconnect couplings and in good condition. Before using the recovery machine, check that it is in satisfactory working order, has been properly maintained and that any associated electrical components are sealed to prevent ignition in the event of a refrigerant release. Consult manufacturer if in doubt.

The recovered refrigerant shall be returned to the refrigerant supplier in the correct recovery cylinder, and the relevant Waste Transfer Note arranged. Do not mix refrigerants in recovery units and especially not in cylinders.

If compressors or compressor oils are to be removed, ensure that they have been evacuated to an acceptable level to make certain that flammable refrigerant does not remain within the lubricant. The evacuation process shall be carried out prior to returning the compressor to the suppliers. Only electric heating to the compressor body shall be employed to accelerate this process. When oil is drained from a system, it shall be carried out safely.

- Decommissioning

Before carrying out this procedure, it is essential that the technician is completely familiar with the equipment and all its detail. It is recommended good practice that all refrigerants are recovered safely. Prior to the task being carried out, an oil and refrigerant sample shall be taken in case analysis is required prior to re-use of reclaimed refrigerant. It is essential that electrical power is available before the task is commenced.

- 1) Become familiar with the equipment and its operation.
- 2) Isolate system electrically.
- 3) Before attempting the procedure ensure that:
 - Mechanical handling equipment is available, if required, for handling refrigerant cylinders;
 - All personal protective equipment is available and being used correctly;
 - The recovery process is supervised at all times by a competent person;
 - Recovery equipment and cylinders conform to the appropriate standards.

- 4) Pump down refrigerant system, if possible
- 5) If a vacuum is not possible, make a manifold so that refrigerant can be removed from various parts of the system.
- 6) Make sure that cylinder is situated on the scales before recovery takes place.
- 7) Start the recovery machine and operate in accordance with manufacturer's instructions.
- 8) Do not overfill cylinders. (No more than 80 volume liquid charge).
- 9) Do not exceed the maximum working pressure of the cylinder, even temporarily.
- 10) When the cylinders have been filled correctly and the process completed, make sure that the cylinders and the equipment are removed from site promptly and all isolation valves on the equipment are closed off.
- 11) Recovered refrigerant shall not be charged into another refrigeration system unless it has been cleaned and checked.

- Charging procedures

In addition to conventional charging procedures, the following requirements shall be Followed.

- 1) Ensure that contamination of different refrigerants does not occur when using charging equipment. Hoses ordines shall be as short as possible to minimize the amount of refrigerant contained in them.
- 2) Cylinders shall be kept upright.
- 3) Ensure that the refrigeration system is earthed prior to charging the system with refrigerant.
- 4) Label the system when charging is complete (if not already).
- 5) Extreme care shall be taken not to overfill the refrigeration system.

Prior to recharging the system, it shall be pressure tested with OFN. The system shall be leak tested on completion of charging but prior to commissioning. A follow up leak test shall be carried out prior to leaving the site.

- The safety wire model is 5*20_5A/250VAC, And must meet the explosion-proof requirements.

- Maintenance of photovoltaic panels

- 1) Clean the glass surface of the component if it is dirty. Clean with a soft sponge dipped in water.
- 2) Perform mechanical and electrical inspection every 6 months to ensure that the components are clean and connected reliably.
- 3) If there is any doubt, please have qualified personnel check.
- 4) Observe the maintenance instructions for all components used in the system, such as bracket, charging rectifier, inverter, battery, etc.
- 5) If there is snow, use a brush with soft bristles to clean the surface of the component.

6. Appendix

6.1. Caution & Warning

- The unit can only be repaired by qualified installer centre personnel or an authorized dealer.
- This appliance is not intended for use by persons (including children) with reduced physical sensory or mental capabilities, or lack of experience and knowledge, unless they have been given supervision or instruction concerning use of the appliance by a person responsible for their safety.
Children should be supervised to ensure that they do not play with the appliance
- Please make sure that the unit and power connection have good earthing, otherwise may cause electrical shock.
- If the supply cord is damaged, it must be replaced by the manufacturer or our service agent or similarly qualified person in order to avoid a hazard.
- Directive 2002/96/EC (WEEE):
The symbol depicting a crossed-out waste bin that is underneath the appliance indicates that this product, at the end of its useful life, must be handled separately from domestic waste, must be taken to recycling centre for electric and electronic devices or handed back to the dealer when purchasing an equivalent appliance
- Directive 2002/95/EC (ROHS): This product is compliant with directive 2002/95/EC (ROHS concerning restrictions for the use of harmful substances in electric and electronic devices.
- The unit CANNOT be installed near the flammable gas. Once there is any leakage of the gas, fire can be occur.
- Make sure that there is circuit breaker for the unit, lack of circuit breaker can lead to electrical shock of fire.
- The heat pump located inside the unit is equipped with an over-load protection system. It does not allow for the unit to start for at least 3 minutes from a previous stoppage.
- The unit can only be repaired by the qualified personnel of an installer centre or an authorized dealer.
- Installation must be performed in accordance with the NEC/CEC by authorized person only.
- USE SUPPLY WIRES SUITABLE FOR 75°C.
- Caution: Single wall heat exchanger, not suitable for potable water connection.

6.2. Cable Specification

Nameplate maximum current	Phase line	Earth line	MCB	Creepage protector	Signal line
< 10A	2 × 1.5mm ²	1.5mm ²	20A	30mA less than 0.1 sec	0.5 mm ²
10-16A	2 × 2.5mm ²	2.5 mm ²	32A	30mA less than 0.1 sec	
16-25A	2 × 4mm ²	4 mm ²	40A	30mA less than 0.1 sec	
25-32A	2 × 6mm ²	6 mm ²	40A	30mA less than 0.1 sec	

6.3. Internal Electrical Wiring Diagram

